



Ruud® Ultra™ & Achiever Plus® Super High Efficiency Gas Water Heaters

MAXIMUM EFFICIENCY.
POWERFUL PERFORMANCE.
SMART CONTROL.



**RUUD®
ULTRA™ SHEG
WITH
LEAKSENSE™**

**RUUD®
ULTRA™ SHEG
HEAVY DUTY
WITH
LEAKSENSE™**

**RUUD®
ACHIEVER
PLUS® SHEG**



These products meet a stringent set of our internally defined sustainability standards.¹

RELY ON RUUD.™

¹Sustainability Standouts applies to premium models only.

Ruud Ultra™ Super High Efficiency Gas with LeakSense™ Premium Models

Ruud® Ultra™ Super High Efficiency Gas with LeakSense and Ultra™ Super High Efficiency Gas Heavy Duty with LeakSense

were designed to give homeowners continuous hot water, MaxMode™ and smart features— all from a water heater that installs as easily as a standard product.



FEATURE	SHEG WITH LEAKSENSE	SHEG HEAVY DUTY	COMPETITOR 1	COMPETITOR 2
LeakGuard™ Auto Shut-Off Valve ¹ Ready	✓	✓	✗	✗
LeakSense™ Integrated Leak Detection System	✓	✓	✗	✗
Integrated Monitoring With Wi-Fi Mobile App	✓	✓	✗	✗
Full-Color LCD Monitoring Display	✓	✓	✗	✗
Air Handler Certified	✓	✓	✗	✗
Built-in Condensate Neutrializer	✓	✓	✗	✗
Flexible Venting	✓	✓	✓	✓

MAXIMUM EFFICIENCY

ENERGY STAR® certified and up to 0.90 UEF reduces energy usage and carbon footprint by up to 36%¹

POWERFUL PERFORMANCE

Fast recovery heats water up to 2X faster than a standard gas tank², enough for up to nine simultaneous showers⁴

SMART CONTROL

Built-in EcoNet® Wi-Fi Technology allows homeowners to control and optimize their water heater experience from a mobile device⁵

SMART PROTECTION

LeakSense™ Leak Detection System detects any water leak—large or small, internal or external⁶

Ruud Achiever Plus® Super High Efficiency Gas Plus Model

Ruud® Achiever Plus® Super High Efficiency Gas

was designed with a powerful, yet efficient burner that helps it outperform, so there's no need to choose between sustainability goals and enjoying hot water.



FEATURE	SHEG PLUS	COMPETITOR 1	COMPETITOR 2
High Altitude (Up to 10,000 feet)	✓	X	X
Error Code Diagnostics	✓	✓	X
ULN Models as low as 10 ng/i	✓	X	X
Installation Verification	✓	X	X
Air Handler Certified	✓	X	X
Built-in Condensate Neutrializer	✓	X	X
Flexible Venting	✓	✓	✓
100% Serviceable From the Front	✓	X	X

MAXIMUM EFFICIENCY

ENERGY STAR® certified and up to 0.90 UEF for carbon footprint reduction with up to a 36%¹ reduction in energy use

POWERFUL PERFORMANCE

Provides up to 25% more hot water than a standard gas tank² so you'll never worry about running out of hot water while you shower, do the dishes and wash the laundry



Maximum Efficiency

As the most efficient water heater in its class, Super High Efficiency Gas is ENERGY STAR® certified and helps deliver up to \$1,100+ in energy cost savings over 12 years.⁸ And it may save even more with available tax credits or local utility rebates.

Earth-Friendly Design

Super High Efficiency Gas was designed with a powerful, yet efficient burner that helps it outperform, so there's no need to choose between sustainability goals and enjoying hot water. It helps homeowners reduce their carbon footprint and energy use by up to 36%¹ and reduce their NOx emissions up to 75%.⁹

Save Water with Recirculation

Pair with a recirculation pump (sold separately) to save over 12,000 gallons of water from being wasted down the drain each year.¹⁰ (premium models)

Space Heating Ready

Side water connections built-in for use with a space heating, hydronic air handler—no need for a second tank or a furnace.



This product meets a stringent set of our internally defined sustainability standards

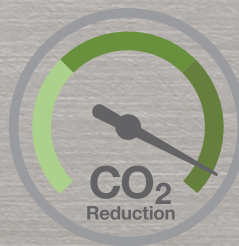

This Product Demonstrates a BRAND BEST Level of CO₂ Reduction*

**As compared to our baseline product*



Smart Control

PREMIUM MODELS

Wi-Fi Monitoring

With integrated Wi-Fi and the EcoNet® App, homeowners can enjoy complete control—like adjusting water temperature and setting Vacation / Away or MaxMode™—and know when their water heater needs service. It's all possible with the Ruud® Super High Efficiency Gas Water Heater.

Hot Water Availability Indicator

Know how much hot water is available before jumping into the shower.

Scheduling

Program the water heater to match household needs throughout the day.

Mobile Alerts

Receive immediate notifications of leaks and service needs through the EcoNet App⁵.

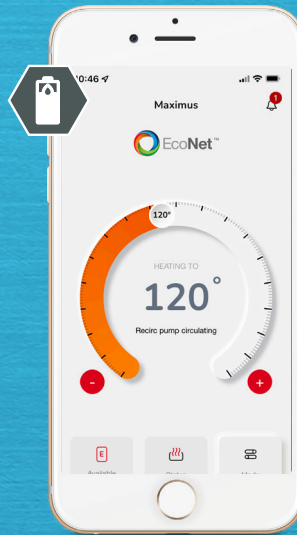

Total Control

Check hot water availability, adjust the temperature or turn on a recirculation pump accessory.

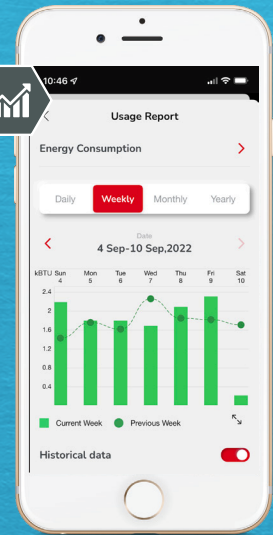

Energy Usage Tracking

View weekly, monthly and yearly energy usage reports to better manage consumption⁵.

NOTE: EcoNet App subject to change without notice.

Smart Protection

PREMIUM MODELS

Leak Detection

Super High Efficiency Gas was designed with homeowner comfort and safety in mind. It features LeakSense™ leak detection system that detects any leak—large or small, internal or external—in less than 15 seconds⁶ and alerts the homeowner through the EcoNet App and on-unit display.

Add Leak Prevention

When you add a LeakGuard™ Auto Water Shut-off Valve Kit (Part SP21172), Super High Efficiency Gas can stop leaks before they become a problem. LeakGuard protects your homeowners' belongings by limiting leaks to no more than 20 ounces¹¹.



Powerful Performance

With an efficient yet powerful burner, a 50-gallon Super High Efficiency Gas produces up to 2.5X the hot water of a standard tank. So homeowners will never worry about running out of hot water while they do the dishes, wash the laundry or even run continuous back-to-back showers.

MaxMode™

Gives the water heater the boost it needs to keep up when demand is high, producing up to 15% more hot water.¹² So even with houseguests, homeowners are covered.



Hot Water Performance

Delivery:

Gallons of hot water produced per hour, starting with a full tank.

- STANDARD FHR
- MAXMODE DELIVERY

Enjoy More Hot Water With Super High Efficiency Gas

In MaxMode, Super High Efficiency Gas provides up to 15% more Hot Water

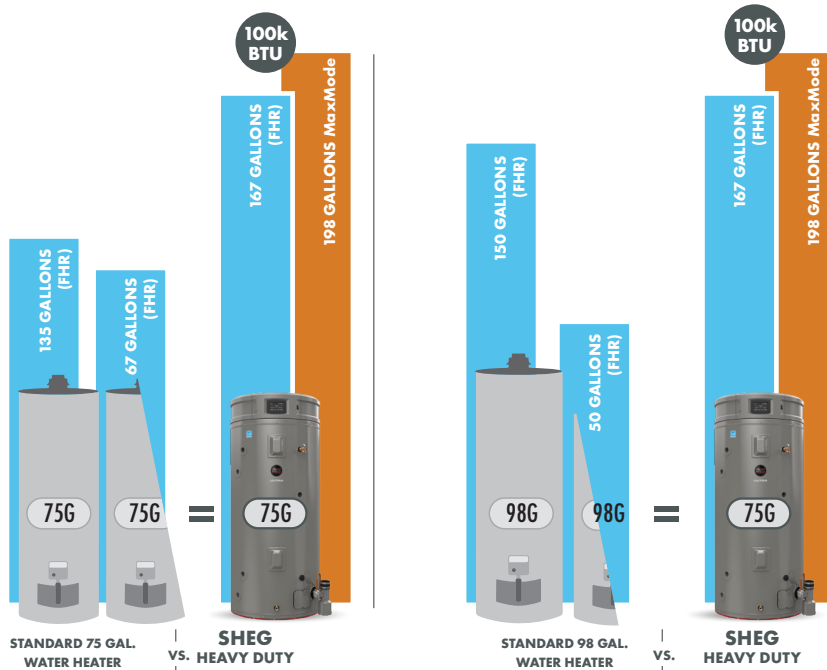
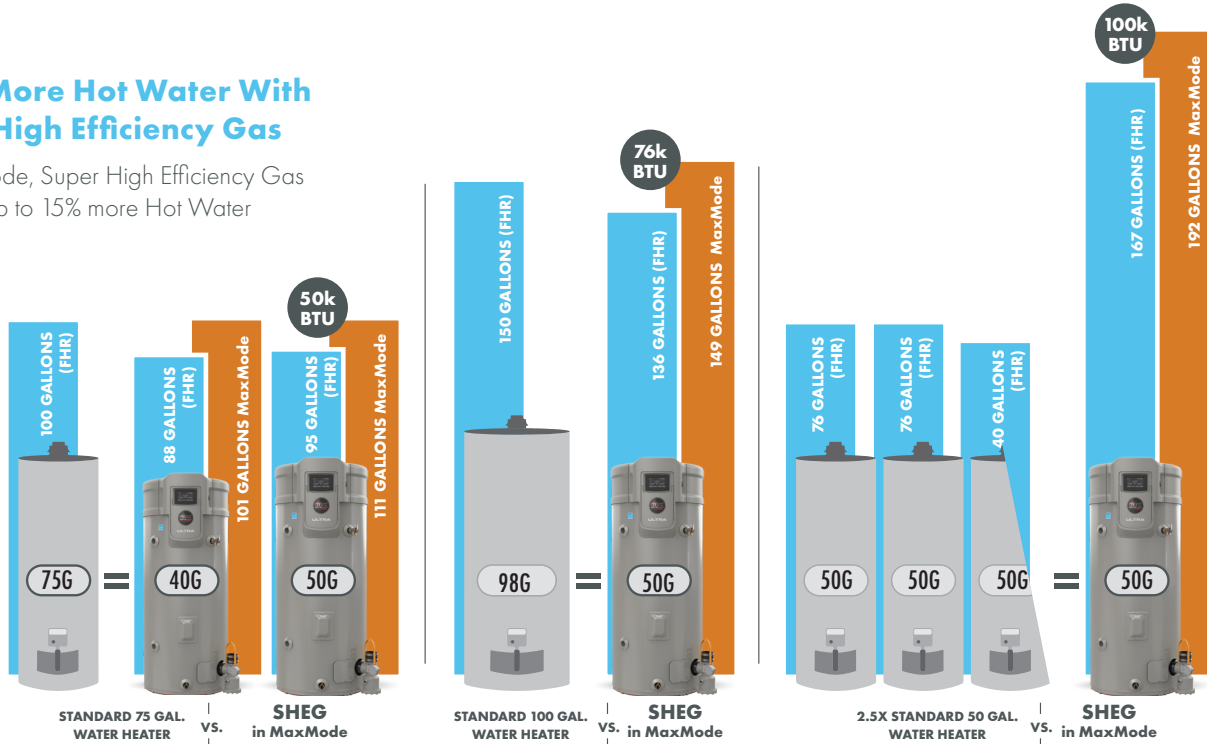

Fast Recovery

Replenishes hot water up to 2X faster than a standard gas tank to provide continuous hot water, up to 3.8 Gallons Per Minute¹³, so you can take as many showers back-to-back as you need. With the tank capacity added to the fast recovery, Super High Efficiency Gas is capable of providing hot water for up to nine simultaneous showers.*

CONTINUOUS HOT WATER FROM SUPER HIGH EFFICIENCY GAS

	Inlet Temperature 45°	Inlet Temperature 58°	Inlet Temperature 70°
Models:	Approximate Usage	Approximate Usage	Approximate Usage
40G-50K			
50G-50K			
50K-76K			
50G-100K			
75G-100K			

Total simultaneous hot water flow for a continuous duration.

TOTAL # OF SHOWERS 120°F SET-POINT 2 GPM SHOWER			
Models:	Inlet Temperature 45°	Inlet Temperature 58°	Inlet Temperature 70°
40G-50K			
50G-50K			
50K-76K			
50G-100K			
75G-100K			

TOTAL # OF SHOWERS 140°F SET-POINT 2 GPM SHOWER			
Models:	Inlet Temperature 45°	Inlet Temperature 58°	Inlet Temperature 70°
40G-50K			
50G-50K			
50K-76K			
50G-100K			
75G-100K			

Total simultaneous hot water flow for an 8 minute duration.

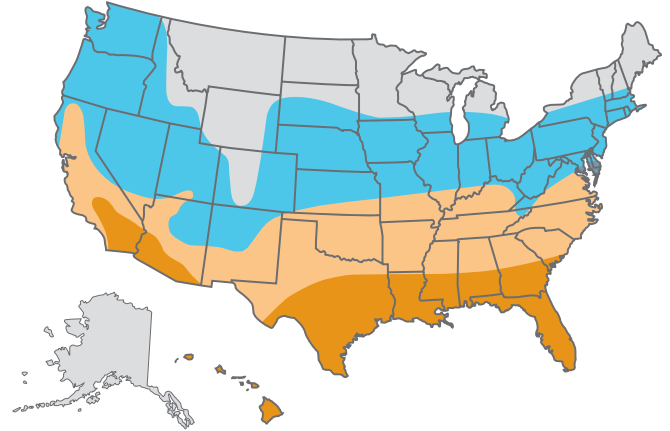

Flow rates are dependent on the inlet water temp. Gray zone flow rates will typically be less than other zones.

- 45°F Inlet Temperature
- 58°F Inlet Temperature
- 70°F Inlet Temperature

USAGE KEY

- Shower
Flow rate of 2.0 GPM
- Faucet
Flow rate of 1.0 GPM

Inlet Temperature:
The temperature of cold water before it enters your water heater.

Approximate Usage:
Shower temperature of 105° F. Flow rates vary depending on temperature of incoming cold water and water heater set temperature.



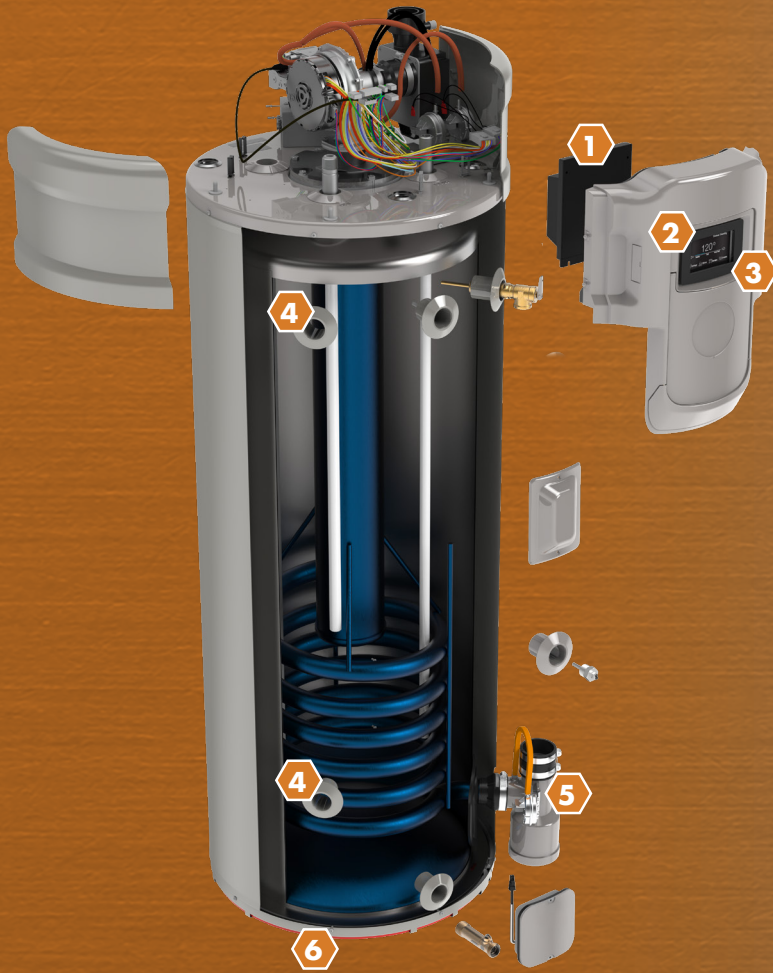

Built to be better for the Homeowner—and You

Super High Efficiency Gas Product Features

Not only did we make it easy to install and service, but we also made it powerful, smart and dependable. So when you're looking for a gas water heater for your homeowners, why look for the best when you can install the greatest?

Ruud® Ultra™ Super High Efficiency Gas with LeakSense™ Premium Model

- 40 and 50-Gallon Capacities
- 50K - 100K BTU/h
- Super High Efficiency – Up to .90 UEF
- 1** • Advanced Controls and Start-up Verification
- 2** • Touchscreen LCD Display with System Health Alerts
- 3** • Integrated EcoNet® Smart Wi-Fi Monitoring Technology
- Side Water Connections for Space Heating
- 4** • Built-in Condensate Neutralizer
- 5** • LeakSense™ Built-in 360° Leak Detection System
- 6** • MaxMode™ for up to 15% More Hot Water on Demand
- 12-Year Warranty

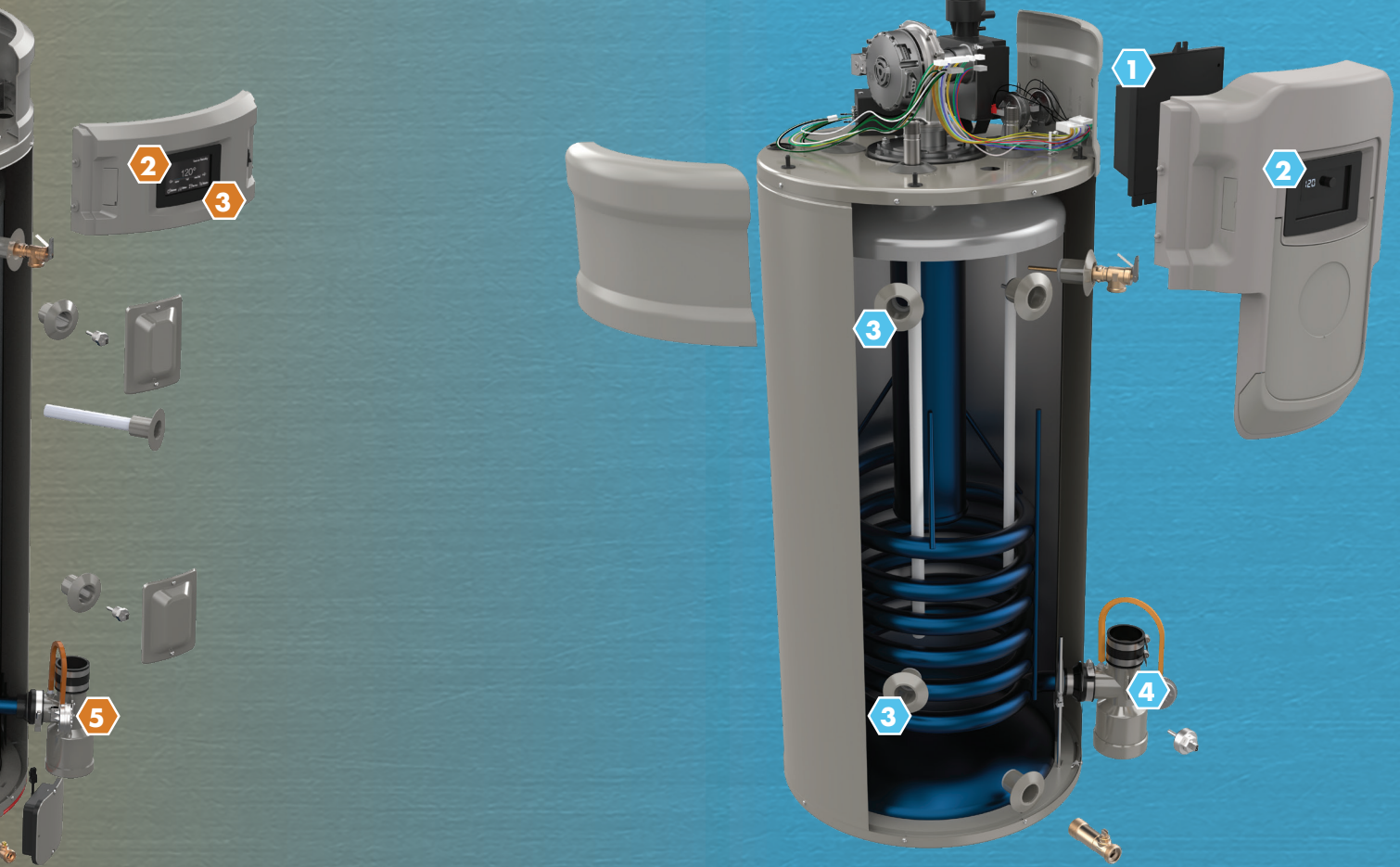

Ruud® Ultra™ Super High Efficiency Gas Heavy Duty Premium Model

- 75-Gallon Capacity
- 100K BTU/h
- Super High Efficiency – Up to .88 UEF
- 1** • Advanced Controls and Start-up Verification
- 2** • Touchscreen LCD Display with System Health Alerts
- 3** • Integrated EcoNet® Smart Wi-Fi Monitoring Technology
- 4** • Side Water Connections for Space Heating
- 5** • Built-in Condensate Neutralizer
- 6** • LeakSense™ Built-in 360° Leak Detection System
- MaxMode™ for up to 15% More Hot Water on Demand
- 12-Year Warranty

Ruud® Achiever Plus® Super High Efficiency Gas Plus Model

- 40 and 50-Gallon Capacities
- 50K BTU/h
- Super High Efficiency – Up to .90 UEF
- 1** • Start-up Verification
- 2** • LCD Display with Integrated Diagnostics
- 3** • Side Water Connections for Space Heating
- 4** • Built-in Condensate Neutralizer
- 8-Year Warranty



Ruud® Ultra™ Super High Efficiency Gas with LeakSense™ / Ruud® Ultra™ Super High Efficiency Gas Heavy Duty with LeakSense™

Specifications

DESCRIPTION				FEATURES								ROUGHING IN DIMENSIONS (SHOWN IN INCHES)											ENERGY INFO.
TYPE	NOMINAL GALLON CAP.	RATED GALLON CAP.	MODEL NUMBER	GAS INPUT IN THOUS. BTU/H		RECOVERY IN G.P.H. 90° F RISE		FIRST HR. RATING (GALLONS)		MAXMODE™ DELIVERY (GALLONS)		HEIGHT TO INTAKE A	OVERALL UNIT HEIGHT B	DIAM. C	HT. TO GAS CONN. D	VENT SIZE E	WATER CONN. CENTER F	HT. TO SIDE TAP HOT G	HT. TO SIDE TAP COLD H	HT. TO EXHAUST J	WATER CONN. SIZE	SHIP WT. (LBS)	UNIFORM ENERGY FACTOR (UEF)
				NAT.	LP	NAT.	LP	NAT.	LP	NAT.	LP												
Tall	40	40	PROP G40-50U RH HE EC3	50	-	64	-	88	-	101	-	54-1/4	54-1/2	21-3/4	50-1/4	2", 3", 4", 2" or 3" Flex	8	38	12	10	3/4	221	0.90
Tall	40	40	PROP G40-50P RH HE EC3	-	50	-	64	-	88	-	101	54-1/4	54-1/2	21-3/4	50-1/4	2", 3", 4", 2" or 3" Flex	8	38	12	10	3/4	221	0.90
Tall	50	50	PROP G50-50U RH HE EC3	50	-	64	-	95	-	109	-	64-1/4	65-1/2	21-3/4	61	2", 3", 4", 2" or 3" Flex	8	48	12	10	3/4	247	0.88
Tall	50	50	PROP G50-50P RH HE EC3	-	50	-	64	-	95	-	109	64-1/4	65-1/2	21-3/4	61	2", 3", 4", 2" or 3" Flex	8	48	12	10	3/4	247	0.88
Tall	50	50	PROP G50-76U RH HE EC3	76	-	97	-	136	-	156	-	64-1/4	65-1/2	21-3/4	61	2", 3", 4", 2" or 3" Flex	8	48	12	10	3/4	256	0.89
Tall	50	50	PROP G50-76P RH HE EC3	-	76	-	97	-	136	-	156	64-1/4	65-1/2	21-3/4	61	2", 3", 4", 2" or 3" Flex	8	48	12	10	3/4	256	0.89
Tall	50	50	PROP G50-100U RH HE EC3	100	-	128	-	167	-	192	-	64-1/4	65-1/2	21-3/4	61	2", 3", 4", 2" or 3" Flex	8	48	12	10	3/4	256	0.89
Tall	50	50	PROP G50-100P RH HE EC3	-	100	-	128	-	167	-	192	64-1/4	65-1/2	21-3/4	61	2", 3", 4", 2" or 3" Flex	8	48	12	10	3/4	256	0.89
Tall	75	75	PROPG75-100U RH HE EC3	100	-	129	-	167	-	198	-	62-5/8	64-1/2	26-1/4	60-1/8	2", 3", 4", 2" or 3" Flex	12	47	12	9	3/4	332	0.88
Tall	75	75	PROPG75-100P RH HE EC3	-	100	-	129	-	167	-	198	62-5/8	64-1/2	26-1/4	60-1/8	2", 3", 4", 2" or 3" Flex	12	47	12	9	3/4	332	0.88

Uniform Energy Factor and rated gallon capacity based on Department of Energy (DOE) requirements. All units have integrated Wi-Fi control board.

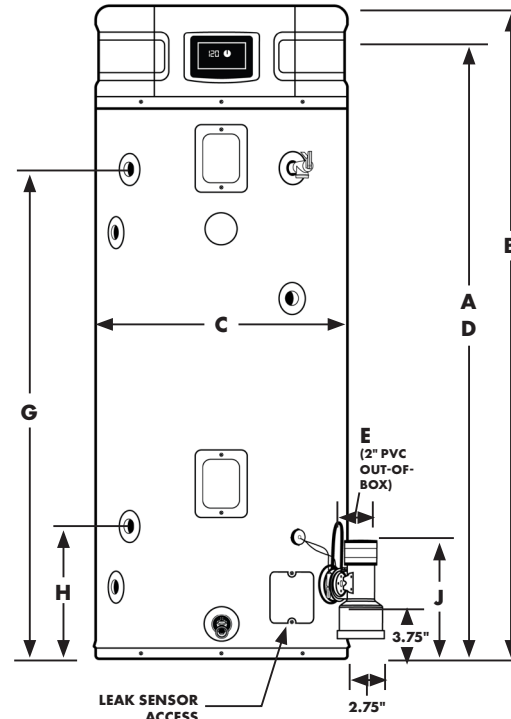
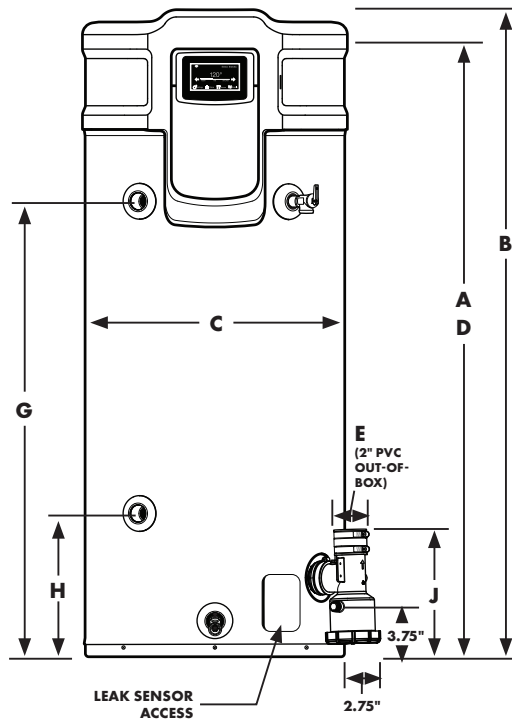

Ruud® Achiever Plus® Super High Efficiency Gas

Specifications

DESCRIPTION				FEATURES						ROUGHING IN DIMENSIONS (SHOWN IN INCHES)												ENERGY INFO.
TYPE	NOMINAL GALLON CAP.	RATED GALLON CAP.	MODEL NUMBER	GAS INPUT IN THOUS. BTU/H		RECOVERY IN G.P.H. 90° F RISE		FIRST HR. RATING (GALLONS)		HEIGHT TO INTAKE A	OVERALL UNIT HEIGHT B	DIAM. C	HT. TO GAS CONN. D	VENT SIZE E	WATER CONN. CENTER F	HT. TO SIDE TAP HOT G	HT. TO SIDE TAP COLD H	HT. TO EXHAUST J	WATER CONN. SIZE	SHIP WT. (LBS)	UNIFORM ENERGY FACTOR (UEF)	
				NAT.	LP	NAT.	LP	NAT.	LP													
Short	40	40	PRO+G40-50U RH HE EC1	50	-	64	-	88	-	54-1/4	54-1/2	21-3/4	50-1/4	2", 3", 4", 2" or 3" Flex	8	38	12	10	3/4	221	0.90	
Short	40	40	PRO+G40-50P RH HE EC1 (H)	-	50	-	64	-	88	54-1/4	54-1/2	21-3/4	50-1/4	2", 3", 4", 2" or 3" Flex	8	38	12	10	3/4	221	0.90	
Tall	50	50	PRO+G50-50U RH HE EC1	50	-	64	-	95	-	64-1/4	65-1/2	21-3/4	61	2", 3", 4", 2" or 3" Flex	8	48	12	10	3/4	247	0.88	
Tall	50	50	PRO+G50-50P RH HE EC1 (H)	-	50	-	64	-	95	64-1/4	65-1/2	21-3/4	61	2", 3", 4", 2" or 3" Flex	8	48	12	10	3/4	247	0.88	

Uniform Energy Factor and rated gallon capacity based on Department of Energy (DOE) requirements.

(H) denotes model is available in high-altitude version. High-altitude versions are required for LP installations at 2000-7800 ft. To order a high-altitude model, add H and the end of the base model number.

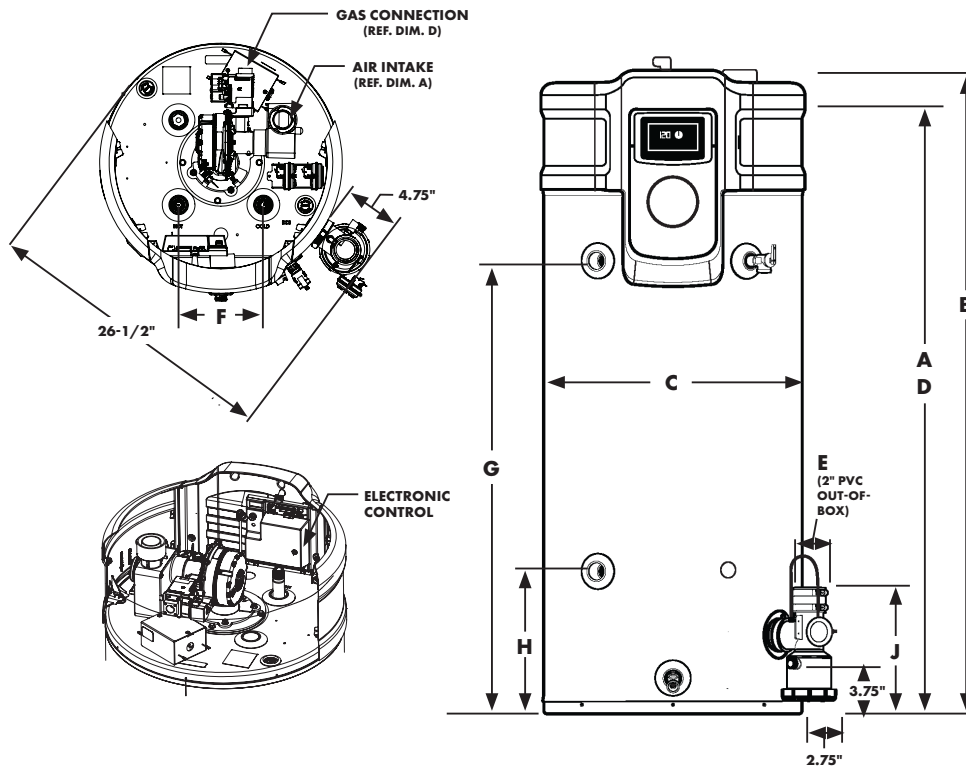

Why Super High Efficiency Gas?

Ruud® Super High Efficiency Gas is what you've been waiting for. Now you can give more homeowners the continuous hot water they want without the costs typically required, from a tank that installs no different than the many you've installed before. Because Super High Efficiency Gas was designed by plumbers and perfected by Ruud engineering, it's a win-win solution that makes you come out looking like a hero.



Advanced Diagnostics

View detailed diagnostics, alerts and alarm codes while at the water heater to expedite service.



Start Up Verification

Be 100% sure your customer is up and running before you leave the job to prevent callbacks.



Leak Sensor Channel

Leak sensor replacement is easy by opening the thermostat panel and snaking the new leak sensor down the channel—360° protection, all from the front of the tank.



Perfect for Replacement

Easy replacement with the same dimensions as a standard gas water heater.



2" Clearance on Sides

Fits in a closet and is fully serviceable from the front.



Contact Info in the App

If anything ever goes wrong, your contact info in the EcoNet® App gives homeowners an easy way to reach and share codes with you for repeat business and simpler service calls.



LEARN MORE
Ruud.com/SHEG

CONTACT US

Customer Service, Warranty and Parts: 800.621.5622

Technical Service: 800.HEATER3 (800.432.8373)

EcoNet® Support: 800.255.2388

Plumber Support Group: 866.339.2388



¹Comparison of a 40 and 50-gallon SHEG to a standard atmospheric gas tank of like capacity with minimum efficiency. ²Recovery comparison of SHEG to atmospheric and PV/conventional vent gas tanks. ³Comparison of the MaxMode™ delivery of a 50-gallon Ruud® SHEG to first hour rating of a standard 50-gallon gas water heater. ⁴Based on 2 GPM shower flow of hot water at 70°F inlet water temperature and 140° F tank water set point temperature. ⁵Wi-Fi broadband connection and EcoNet® App required, connection between water heater and app are dependent on external factors beyond Ruud's control. ⁶Water leaks from the heater only, as tested across scenarios including a minimum of 5.5 mL/hr volume leak rate, using most common installation scenarios. Time starts when leak begins and ends when sensor alarm is triggered. ⁷Based on comparison of the First Hour Rating of a 50-gallon Ruud® SHEG to a standard 50-gallon gas water heater. ⁸Based on AOC (annual operating cost) comparison of 40 and 50-gallon Ruud SHEG Gas Water Heaters to standard gas water heaters of like capacity with minimum efficiency. ⁹Comparison of SHEG to a standard atmospheric gas water heater, not to exceed 75,000 BTUs. ¹⁰Applies to models with a recirculation pump installed only. Recirculation pump sold separately. Claim based on recirculation pump that runs 24/7 with no controls or smart features, for a period of one year. ¹¹Applies to models with auto shut-off valve installed only. Testing under a vacuum lock using 50-gallon tank, no expansion tank, average tank pressure of 40 psi, assuming no additional faucets are opened. ¹²Comparison of SHEG delivery in normal mode to SHEG first hour rating in MaxMode™. ¹³GPM varies by model and inlet water and tank water set point temperature.

*Apple and the Apple logo are trademarks of Apple Inc., registered in the U.S. and other countries. App Store is a service mark of Apple Inc., registered in the U.S. and other countries. Google Play and the Google Play logo are trademarks of Google LLC.

In keeping with its policy of continuous progress & program improvement, Ruud reserves the right to make changes without notice.

PRINTED IN THE USA • 12/23 • WP • RU-SHEG-102-FMLY

