



Ruud® Hybrid Electric Heat Pump Water Heater

Designed for Residential Builders to Maximize Energy Design Rating / HERS Rating

Product Highlights

- 3.50 UEF
- Meets NEEA Tier 3 Requirements
- Powered by EcoNet® Technology
- California Title 24 Compliant (JA13 Ready)
- LeakSense™ Accessory Ready
- Design Certified to NSF/ANSI 372 (lead control)
- QMID: K3A8
- 10 Year Limited Warranty¹



FEATURES & BENEFITS	
High Efficiency	ENERGY STAR® 5.0 certified
	Helps builders earn 45L tax credits
Easy Installation	Easily Ducted – for installation in confined spaces with minimal make up air
	Easy access to universal top and side water connections and top electrical junction box; <i>Zero clearance required in the back or side of the unit</i>
	¾" NPT water inlet & outlet; ¾" condensate drain connections
	Dry fire protection
Available EcoNet® Smart Technology	Built-in Wi-Fi powered by EcoNet® technology ²
	Energy usage reporting
	Energy saving scheduling and operating modes

Hybrid Electric Heat Pump - Builder
 40, 50, 65 and 80-Gallon Capacities
 208-240 Volt / 1 PH / 24 Amps



LEED Points = 3

DESCRIPTION					ENERGY INFO.	FEATURES				
NOMINAL GALLON CAPACITY	RATED GALLON CAPACITY	MODEL NUMBER	MODEL VARIANT	ELECTRIC BREAKER SIZE	UNIFORM ENERGY FACTOR (UEF)	COMPRESSOR BTU/H	FIRST HR. RATING G.P.H.	RECOVERY IN G.P.H. 90° F RISE	UNIT WT. (LBS)	APPROX. SHIP WT. (LBS.)
40	36	PROUH40 T2 RU350BM	703789	30	3.50	4200	60	26	156	177
50	45	PROUH50 T2 RU350BM	703790	30	3.50	4200	67	26	172	193
65	59	PROUH65 T2 RU350BM	703791	30	3.50	4200	75	26	225	262
80	72	PROUH80 T2 RU350BM	703792	30	3.50	4200	87	26	244	281

Uniform Energy Factor and rated gallon capacity based on Department of Energy (DOE) requirements.

Units meet or exceed ANSI requirements and have been tested according to D.O.E. procedures. Units meet or exceed the energy efficiency requirements of NAECA, ASHRAE standard 90, ICC Code and all state energy efficiency performance criteria.

¹ See Residential Warranty Certificate for complete information. ² Wi-Fi broadband internet connection required. ³ Consult your tax advisor for details on eligibility requirements for any available tax credits. Rebates vary by state.

This equipment contains refrigerant R-134A, which complies with New York State regulations (NYCRR Part 494).

Ruud® Hybrid Builder Residential Electric Water Heater

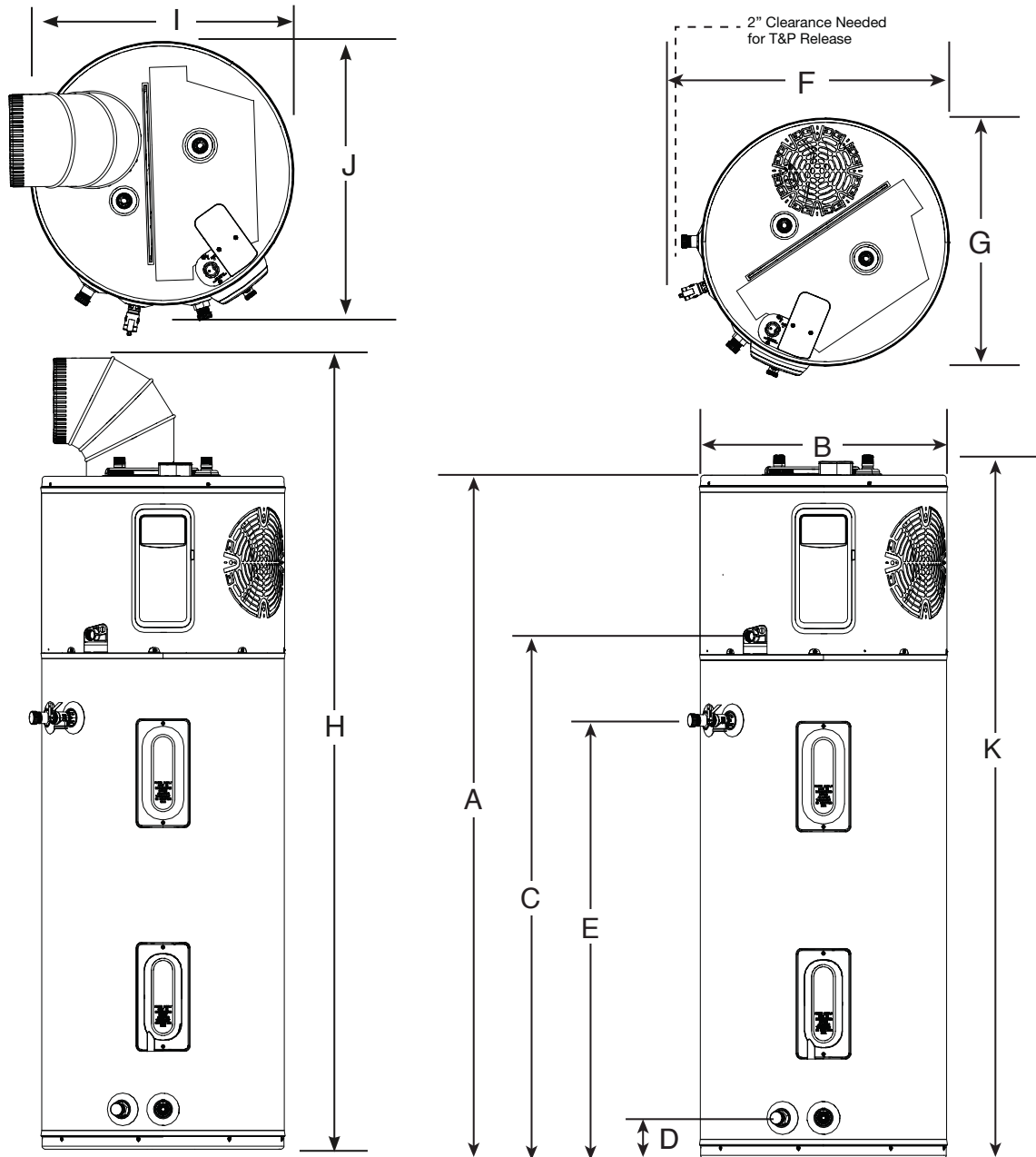

NOMINAL GALLON CAPACITY	DESCRIPTION	DIMENSIONS (SHOWN IN INCHES)									
		A	B	C	D	E	F	G	H	I	J
40	PROUH40 T2 RU350BM	62-5/16	20-1/4	47	3-5/8	39-5/8	25-1/4	20-1/2	78-7/8	22-3/8	21-3/4
50	PROUH50 T2 RU350BM	61-3/4	22-1/4	47	3-5/8	39-5/8	27-1/8	22-1/2	78-5/8	24-3/8	23-5/8
65	PROUH65 T2 RU350BM	64-3/16	24-1/4	49	3-7/8	42-3/8	29-5/16	24-5/8	81-1/8	26-1/2	25-13/16
80	PROUH80 T2 RU350BM	74-3/16	24-1/4	59	3-7/8	52-3/8	29-1/4	24-5/8	91	26-1/2	25-11/16

Hybrid Electric Heat Pump Water Heater Installation Guidelines to Provide Optimal Efficiency

Heater: Not Ducted

Room size: Larger than 700 ft³ (e.g. 7' x 10' x 10').

Requirements:
No additional ventilation needed

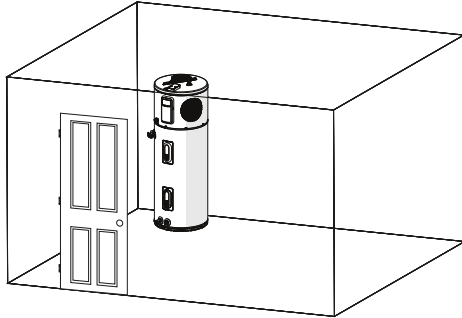

Heater: Not Ducted

Room size: Smaller than 700 ft³ (e.g. 7' x 10' x 10').

Requirements:
Full louvered door OR two louvers top and bottom¹

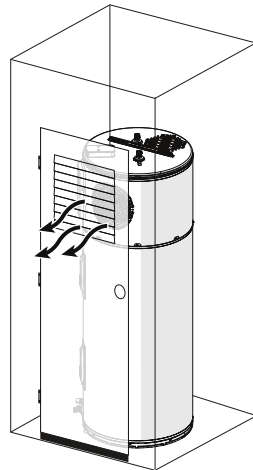
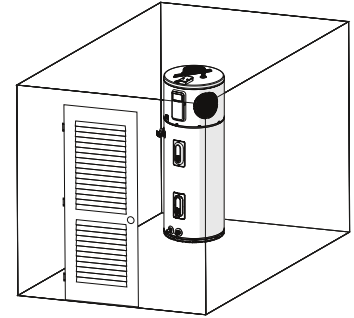

Heater: Not Ducted

Room: Small Closet

Requirements:

- Air gap under door equal to 18 in² (0.75" clearance)
- Louver must be located the same height on door as the air exhaust on heater
- Heater air exhaust must be positioned towards louver within one foot of door

PLEASE NOTE: For all non-ducted applications, ensure that the air exhaust vent is oriented to be at least 6" from any walls or solid surfaces to ensure proper dissipation of cooled air.

Heater: Ducted With Inlet or Outlet Duct

Room size:
For all closet installations (size smaller than 400 ft³)

Requirements:
Full louvered door²

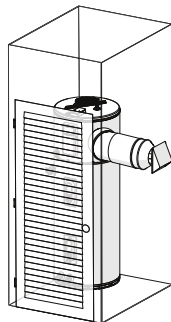

Heater: Ducted With Inlet and Outlet Duct

Room size:
Any size room

Requirements:
No additional ventilation needed

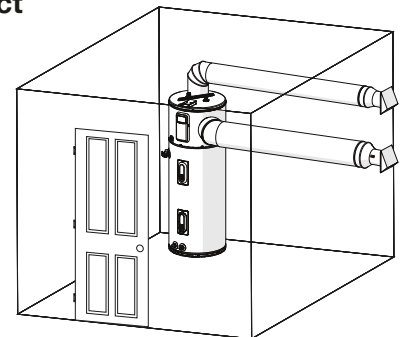

MINIMUM CLEARANCES (WITHOUT DUCTING)		
REAR	SIDES	TOP
0"	0"	6"

FOR EASIER SERVICEABILITY		
REAR	SIDES	TOP
6"	6"	6"

PLEASE NOTE: Heat pump water heater will operate in rooms less than 700 ft³ down to 450 ft³ but at reduced energy efficiency and reduced performance output. Reduced energy efficiency and performance has not been evaluated by Rheem Manufacturing and not recommended for optimal performance of the unit.

¹Minimum louver free opening area required for not ducted room installation application will be 3.25 sq ft.

²Minimum louver free opening area required for ducted closet installation application will be 2.9 sq ft.

Hybrid Builder Accessories

PART NUMBER	DESCRIPTION	USE FOR
SP20882	Earthquake Isolation Kit	Installations in seismic regions
SP20883	Vibration Isolation Kit	Installation on non-concrete floors
SP20884	8" Diameter UL Certified Termination Kit	Termination to the outside or to the attic with 8" diameter
SP20885	7" Diameter UL Certified Termination Kit	Termination to the outside or to the attic with 7" diameter
SP20886	6" Diameter UL Certified Termination Kit	Termination to the outside or to the attic with 6" diameter
SP20887	5" Diameter UL Certified Termination Kit	Termination to the outside or to the attic with 5" diameter
SP20888	8" Ruud Approved Damper Kit	Exhaust only to the outside ducting configuration (no inlet duct)
SP20889	25' Flexible 8" Diameter Duct Kit	For up to 25' of ducting
SP20890	Rigid Elbow Duct Kit	Installation in tight places where space needs to be minimized
SP17829	Outlet Duct Adapter	Allows for ducting to be connected to the unit
AP19134	Leak Sensor	Automatic detection of internal and external leaks
SP21105	Inlet Duct Adapter	Allows for ducting to be connected on the top inlet
FR-80	Little Firefighter Water Heater Front Restraint	Secures the water heater to the wall to prevent damage and water leaks due to severe weather
AP23528	Duct Diverter	Allows for seasonal flexibility in ducting cool exhaust air

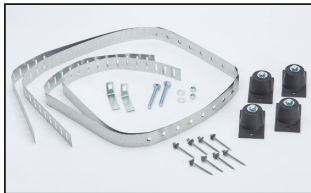

SP20882

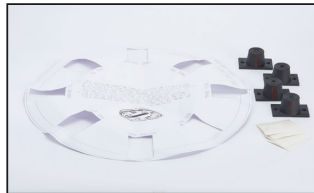

SP20883

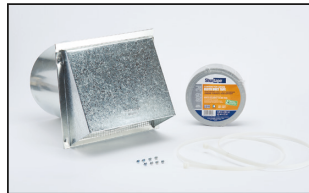

SP20884



SP20885



SP20886



SP20887



SP20888



SP20889



SP20890

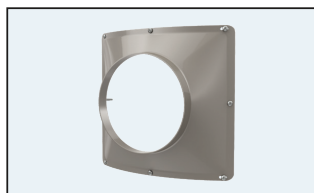

SP17829

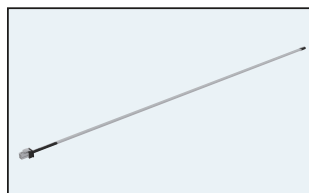

AP19134

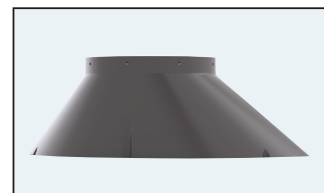

SP21105



FR-80



AP23528

In keeping with its policy of continuous progress and product improvement, Ruud reserves the right to make changes without notice.