



Floating Air™ | ACHIEVER® Series DUCTLESS MINI-SPLIT SYSTEMS

WALL-MOUNTED, SINGLE ZONE HEAT PUMPS

PURCHASER	P.O. #	DATE
PROJECT	LOCATION	
ENGINEER	ARCHITECT	
SUBMITTED BY	FOR APPROVAL	FOR REFERENCE

ITEM	PLAN DESIGNATION	QUANTITY	COOLING BTU/H	VOLTAGE	RUUD MODEL

Indicates sustainability feature

Key Features

- **FastPro®** design for the fastest access for maintenance of any wall-mounted ductless systems
- **Precision Inverter®** technology (variable speed compressor)
- Soft-Start™ compressor
- BLDC motor
- Built-in Wi-Fi
- Sleep mode
- All ENERGY STAR® certified models*
- Ultra quiet operation
- Easy-to-read temperature display
- Low ambient heat pump operation down to -5°F
- Low ambient cooling operation down to 5°F
- Wireless remote

FEATURING **FastPro®** DESIGN



115V: FAHSW09A1C, FAHSW12A1C
230V: FAHFW18A3D, FAHFW24A3D



230V: FAHSW36A3D
(FastPro® not applicable on this model)



FSHSR09B1C, FSHSR12B1C

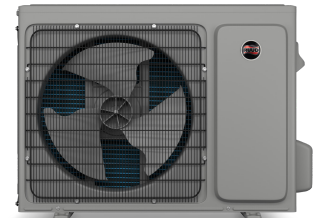
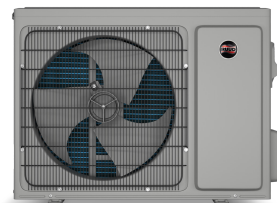

FSHSR18B3D, FSHSR24B3D



FSHSR36B3D

*Applies to FSHW091C and FSHW183D model sets.



FLOATING AIR™ **ACHIEVER®** SERIES | SINGLE-ZONE | WALL-MOUNTED HEAT PUMPS

MODEL	Model Set	Unit	FSHW091C	FSHW121C	FSHW183D	FSHW243D	FSHW363D
	Indoor Model		FAHSW09A1C	FAHSW12A1C	FAHFW18A3D	FAHFW24A3D	FAHSW36A3D
	Outdoor Model		FSHSR09B1C	FSHSR12B1C	FSHSR18B3D	FSHSR24B3D	FSHSR36B3D
	Power Supply		115V~, 60Hz, 1P			208V/230V~, 60Hz, 1P	
	ENERGY STAR® Standard	Y/N	Y	N	Y	N	N
	ENERGY STAR - Cold Climate	Y/N	N	N	N	N	N
COOLING	Rated Capacity @ 95°F	Btu/h	9,000	12,000	18,000	24,000	34,600
	Cooling Capacity Range (Min.-Max.)	Btu/h	3,600-10,000	4,000-13,000	6,500-19,000	8,000-25,000	9,300-36,000
	EER2 @ 95°F	Btu/h/W	12.50	10.20	12.00	10.60	9.50
	SEER2	Btu/h/W	20.00	18.00	21.00	19.50	20.00
	Cooling Operating Range	°F	5°F-118°F	5°F-118°F	5°F-118°F	5°F-118°F	5°F-118°F
HEATING	Rated Capacity @ 47°F	Btu/h	9,500	12,000	18,000	24,000	35,000
	Heating Capacity Range (Min.-Max.)	Btu/h	3,600-10,000	4,000-13,000	6,500-19,000	8,000-25,000	9,600-37,500
	COP2 @ 47°F	W/W	4.10	3.40	3.91	3.30	3.25
	COP @ 5°F	W/W	2.00	1.90	2.40	1.90	1.95
	HSPF2	Btu/h/W	9.00	8.50	9.80	8.50	8.40
	Rated Capacity Heating @ 17°F (-8.3°C)	Btu/h	6,800	8,800	14,800	21,000	19,200
	Maximum Heating Capacity @ 5°F (-15°C)	Btu/h	6,000	7,500	15,000	18,500	20,000
	Heating Operating Range	°F	-5°F-75°F	-5°F-75°F	-5°F-75°F	-5°F-75°F	-5°F-75°F
INDOOR AIRFLOW	Air Circulation (Max/H/M/L)	ft3 CFM	382/341/294/247	394/365/312/253	647/588/482/382	706/647/559/441	1059/1018/883/712
	Sound Rating - Indoor (Max/H/M/L/Quiet)	dB (A)	42/39/37/35/32	42/39/37/35/32	48/45/41/39/36	50/48/43/41/39	52/48/43/39/38
INDOOR FAN MOTOR	Output	W	46	46	35	35	70
	Speed (Hi/Med/Lo)	r/min	1100/940/800	1154/992/800	1100/960/800	1200/1040/880	1060/930/810
OUTDOOR AIRFLOW	Air Circulation (Hi) for Outdoor	ft3 CFM	1,295	1,295	1,471	1,942	2,590
	Sound Rating - Outdoor (Hi)	dB (A)	53.0	53.0	56.0	60.0	60.0
FAN MOTOR	Output	W	36	36	60	102	102
	Speed (Hi)	r/min	850	880	840	880	900
ELECTRICAL	Rated Current	Cooling (A)	6.7	10.7	6.4	10.0	16.0
		Cooling (W)	720	1,176	1,506	2,264	3,660
		Heating (A)	6.2	9.6	8.1	9.5	14.2
		Heating (W)	679	1,034	1,349	2,132	3,160
	MOP (Rating of Overcurrent Protective Device)	A	25	25	20	35	40
MCA (Minimum Circuit Ampacity)	A	14.6	15.6	14.5	21.0	25.8	
Communication Wire Size and Type		4 x 18AWG	4 x 18AWG	4 x 18AWG	4 x 18AWG	4 x 18AWG	
REFRIGERATION (R454B)	Moisture Removal	pints/hr	1.9	2.5	3.8	4.2	7.9
	Refrigerant Charge Volume	oz.	21.2	21.9	45.9	47.7	72.4
	Liquid Pipe	in.	1/4	1/4	1/4	3/8	3/8
	Gas Pipe	in.	3/8	3/8	1/2	5/8	5/8
	Max. Pipe Length (Total)	ft.	65.6	65.6	98.4	98.4	98.4
	Max. Elevation (Indoor Units Higher Than Outdoor Unit)	ft.	49.2	49.2	49.2	49.2	49.2
	Pre-charge Pipe Length	ft.	24.6	24.6	24.6	24.6	24.6
	Additional Refrigerant Charge per Foot after 25 ft.	oz./ft.	0.22	0.22	0.22	0.32	0.43
INDOOR UNIT	Dimension (W×H×D)	in.	33 7/8 × 11 2/8 × 8 4/8	33 7/8 × 11 2/8 × 8 4/8	45 2/8 × 13 2/8 × 10	45 2/8 × 13 2/8 × 10	52 3/8 × 14 2/8 × 10 6/8
		mm	860×285×216	860×285×216	1148×336×256	1148×336×256	1330×363×274
	Packing (L×H×W)	in.	36 5/8 × 15 × 11 2/8	36 5/8 × 15 × 11 2/8	47 7/8 × 16 1/8 × 13	47 7/8 × 16 1/8 × 13	56 1/8 × 15 4/8 × 18 1/8
		mm	930×285×380	930×285×380	1,215 × 330 × 410	1,215×330×410	1,425×395×460
	Net Weight	lbs.	22.1	22.05	32.0	34.2	40.8
		kg	10.0	10.0	15.0	16.0	19.0
Shipping Weight	lbs.	26.5	26.5	37.5	39.7	50.3	
	kg	12.0	12.0	17.0	18.0	23.0	
OUTDOOR UNIT	Dimension (W×H×D)	in.	28 1/8 × 21 2/8 × 9 4/8	28 1/8 × 21 2/8 × 9 4/8	31 7/8 × 23 × 11	33 7/8 × 25 5/8 × 12 2/8	35 3/8 × 29 4/8 × 13 3/8
		mm	715×540×240	715×540×240	810×585×280	860×650×310	900×750×340
	Packing (L×H×W)	in.	32 5/8 × 23 1/8 × 13 3/8	× 23 1/8 × 13 3/8	× 25 2/8 × 15 1/8	× 28 3/8 × 16 4/8	41 6/8 × 32 2/8 × 17 6/8
		mm	830×588×340	830×588×340	940×640×385	995×720×420	1,060×820×450
	Net Weight	lbs.	52.9	57.3	39.0	46.0	55.0
		kg	24.0	26.0	17.7	20.9	25.0
Shipping Weight	lbs.	57.3	61.7	61.7	61.7	132.3	
	kg	26.0	28.0	28.0	28.0	60.0	

Due to continuing research in new energy-saving technology, specifications are subject to change without notice.



**DIMENSIONAL DRAWINGS: WALL-MOUNTED HEAT PUMP
INDOOR UNITS / FAHSW09A1C, FAHSW12A1C**

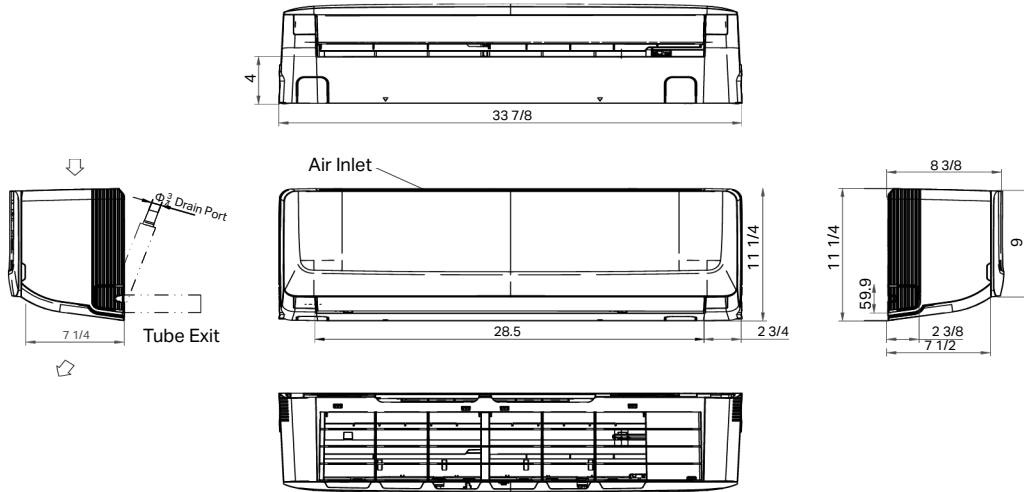

Model	W	H	D
FAHSW09A1C, FAHSW12A1C	33 7/8"	11 2/8"	8 4/8"

UNITS: INCHES (MM)

INDOOR UNITS / FAHFW18A3D, FAHFW24A3D

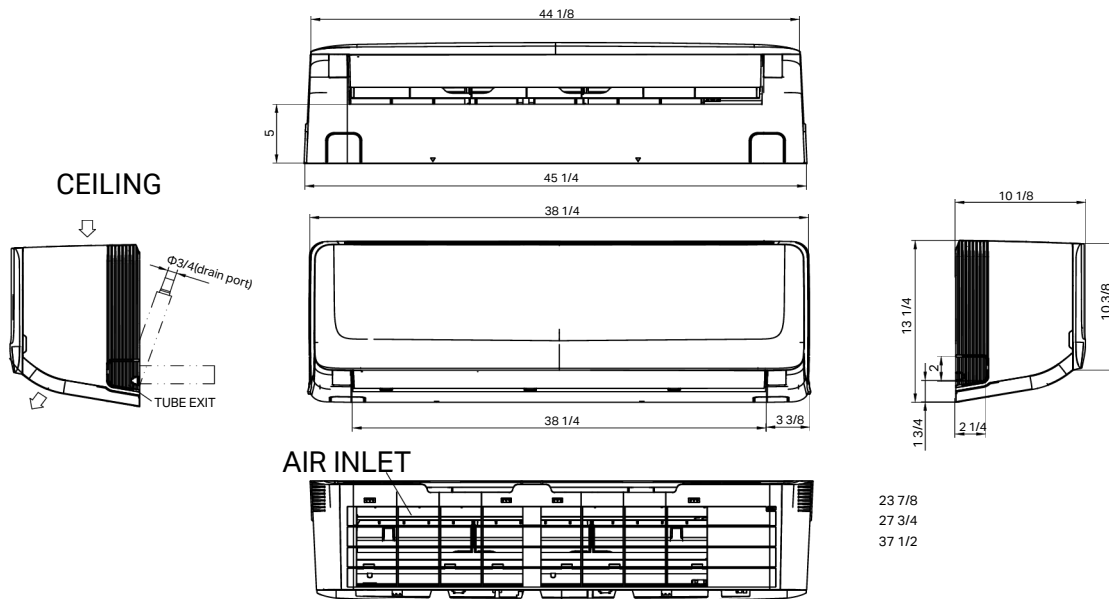

23 7/8
27 3/4
37 1/2

Model	W	H	D
FAHFW18A3D, FAHFW24A3D	45 2/8"	13 2/8"	10 1/8"

UNITS: INCHES (MM)

**DIMENSIONAL DRAWINGS: WALL-MOUNTED HEAT PUMP
INDOOR UNIT / FAHSW36A3D**

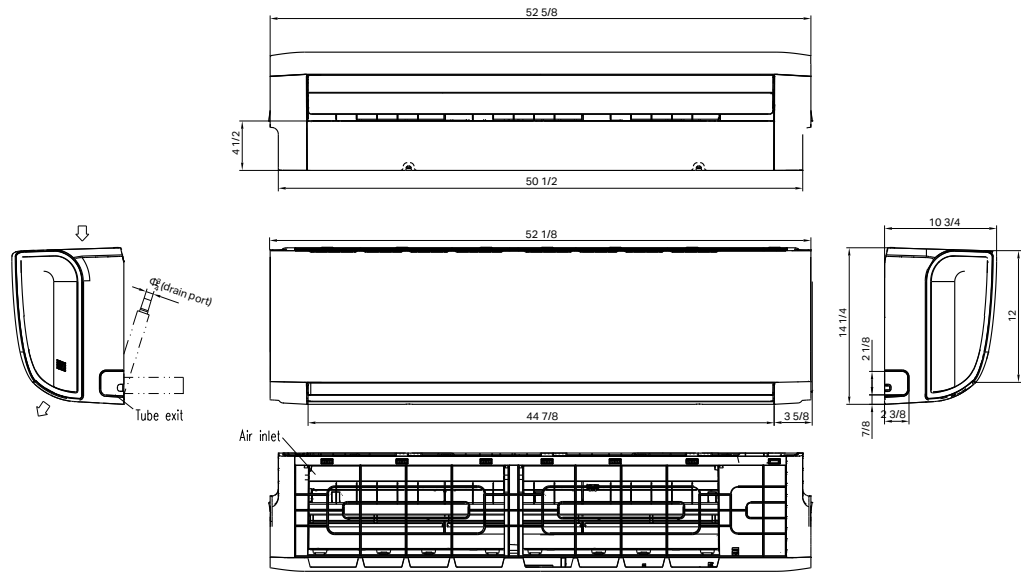

Model	W	H	D
FAHSW36A3D	52 3/8"	14 2/8"	10 6/8"

UNITS: INCHES (MM)

DIMENSIONAL DRAWINGS: OUTDOOR HEAT PUMP

OUTDOOR UNITS / FSHSR09B1C, FSHSR12B1C

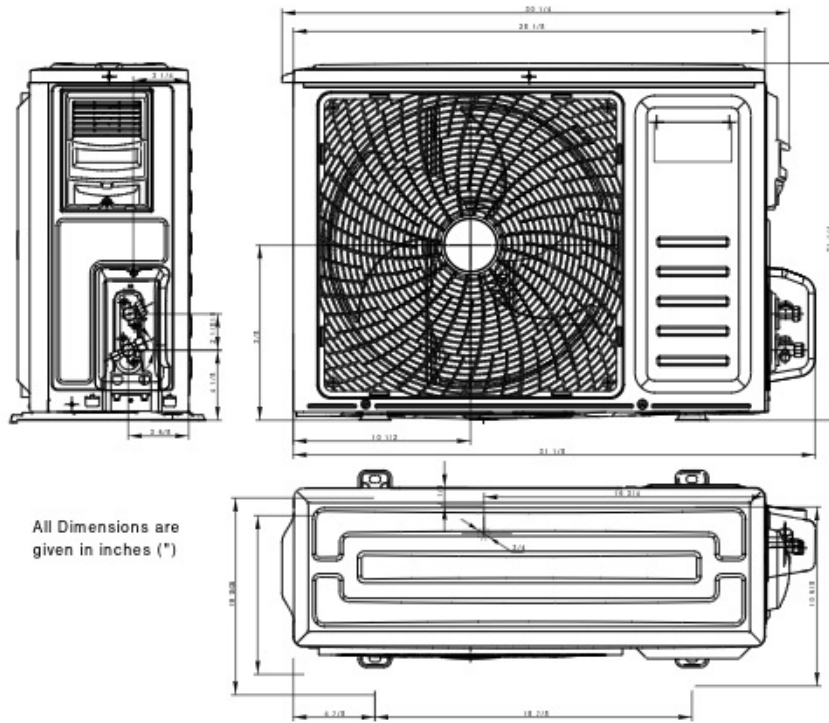

Model	W	H	D
FSHSR09B1C	28 1/8"	21 2/8"	8 4/8"
FSHSR12B1C			

UNITS: INCHES (MM)

OUTDOOR UNITS / FSHSR18B3D

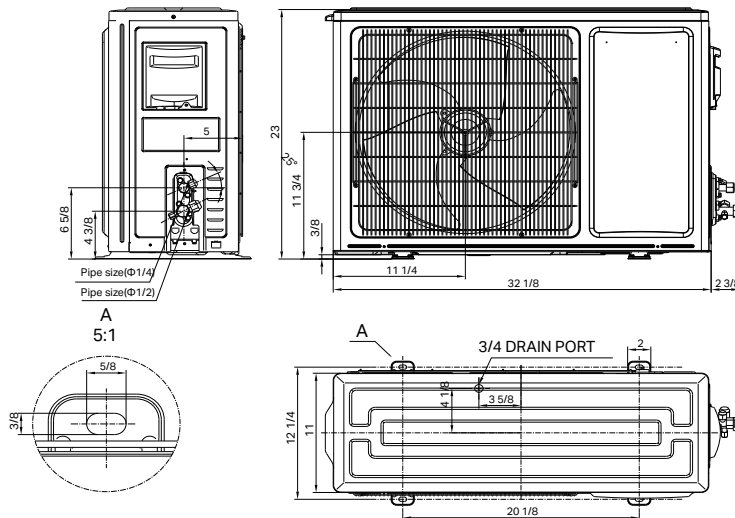

Model	W	H	D
FSHSR18B3D	31 7/8"	23	11

UNITS: INCHES (MM)

DIMENSIONAL DRAWINGS: OUTDOOR HEAT PUMPS

OUTDOOR UNITS / FSHSR24B3D

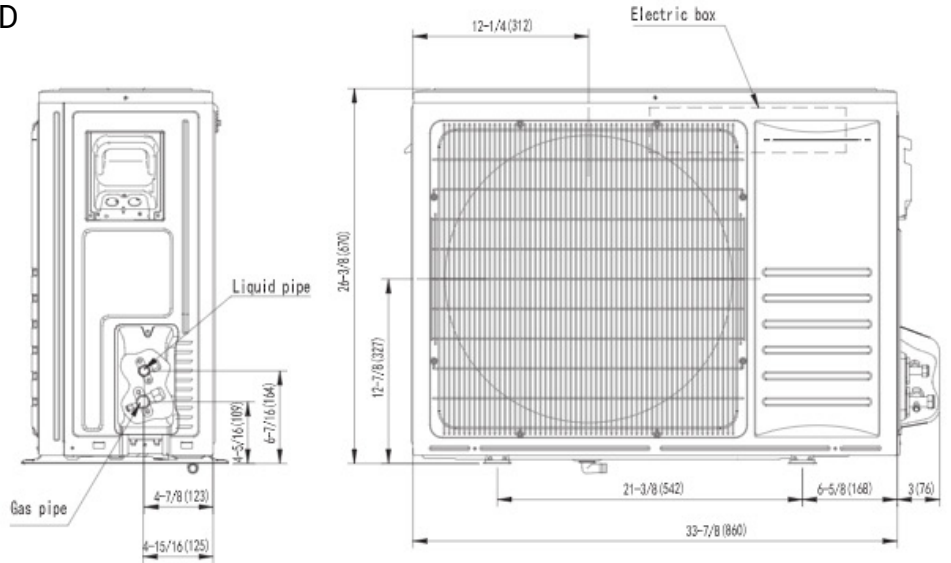

Model	W	H	D
FSHSR24B3D	33 7/8"	27 5/8"	12 2/8"

UNITS: INCHES (MM)

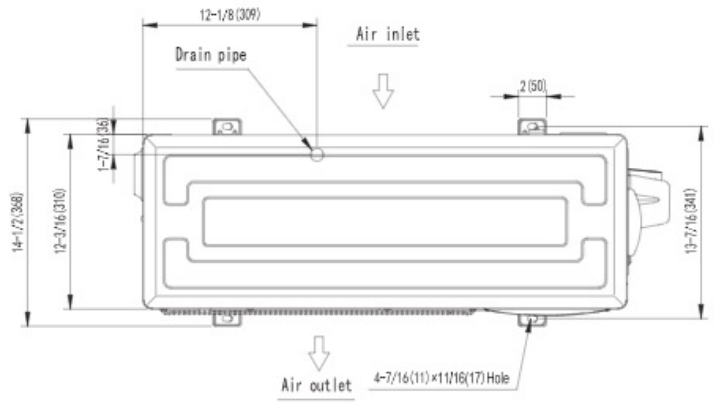

OUTDOOR UNITS / FSHSR36B3D

All Dimensions are given in inches (")

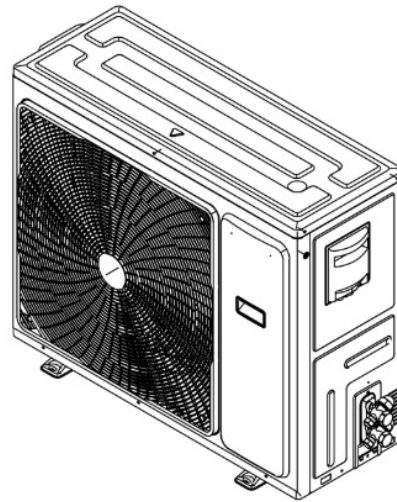
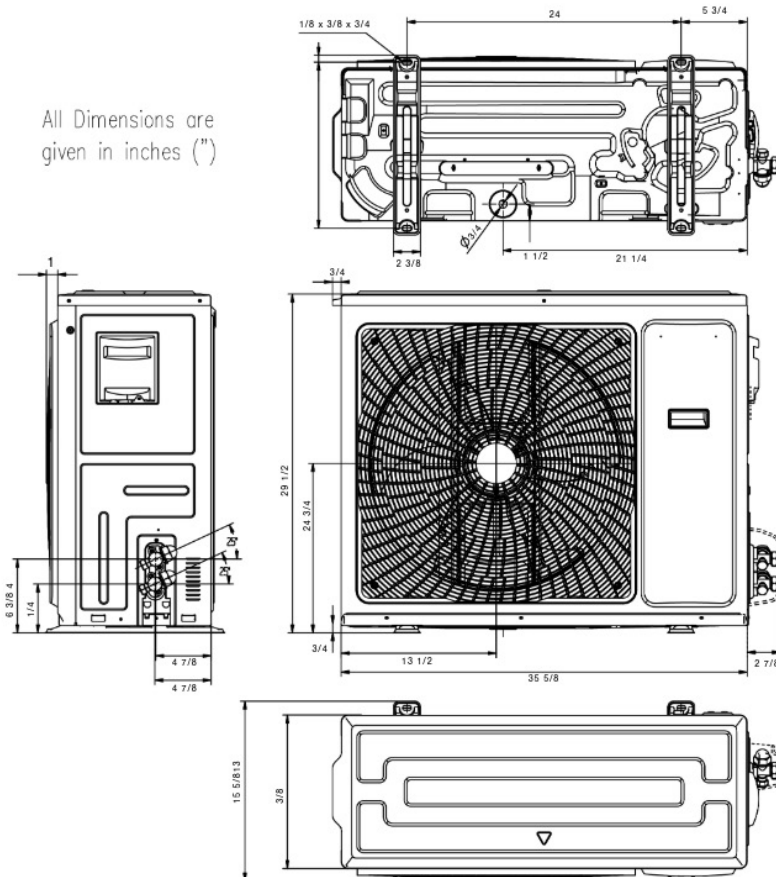

Model	W	H	D
FSHSR36B3D	35 3/8"	29 4/8"	13 3/8"

REFRIGERATION LINE SETS*

Kit#	Length (ft.)	Liquid	Suction	System Model
T32150	15'	1/4"	3/8"	FSHW091C, FSHW121C
T32350	35'	1/4"	3/8"	

Kit#	Length (ft.)	Liquid	Suction	System Model
T42150	15'	1/4"	1/2"	FSHW183D
T53250	25'	3/8"	5/8"	FSHW243D, FSHW363D

*Insulated line sets are available for all Ruud split systems in 15 ft. and 35 ft. lengths. Each line set is equipped with flare nuts on both ends. Both liquid and suction lines are insulated. Line sets can be joined together with field supplied double male connectors. Each system requires one line set for each indoor unit installed.

REFRIGERATION LINE SETS MIN./MAX. LENGTHS

System Model	Min. (ft.)	Max. (ft.)
FSHW091C, FSHW121C	10	66
FSHW183D, FSHW243D	10	98
FSHW363D	15	98

TORQUE WRENCH SETTINGS

Outside Diameter		Torque	
mm	inch	ft-lbs.	N·m
6.35	1/4	13 – 18	17.6 – 24.5
9.52	3/8	25 – 30	33.3 – 41.2
12.7	1/2	40 – 47	53.9 – 64.7
15.88	5/8	45 – 59	61.7 – 80.4

ACCESSORIES



FPWC1 – Optional hard-wired controller for Floating Air wall-mounted and cassette indoor models. Included with concealed ducted models. Not compatible with AHU indoor models. See your Ruud representative for options.



FreshAire Purifier APWM1 by iWave® – Optional accessory for all wall-mounted ductless models that kills mold, bacteria and viruses—while effectively removing odors and VOCs.